

Simulation Study on Performance and Emissions of a Diesel Engine Using Diesel-Ethanol-Waste Cooking Oil Blends

Pham Huu Tuyen¹, Pham Huu Truyen², Hoang Van Thu^{1,2,*}

¹School of Mechanical Engineering, Hanoi University of Science and Technology, Ha Noi, Vietnam

²Vinh University of Technology Education, Nghe An Province, Vietnam

*Corresponding author email: hoangthusky@gmail.com

Abstract

Using biofuel for diesel engines is a sustainable solution to solve the current scarcity of petroleum energy sources and environmental pollution problems. The paper presents performance and emissions of a Hyundai D4BB diesel engine when using diesel-ethanol-waste cooking oil (WCO) blends modeled by AVL Boost software. The test blends comprised 5% of WCO, and 10%, 20%, 30% of ethanol, and fossil diesel in the rest. Estimated viscosities of the blends were in the range of 2 – 4.5 mm²/s, equivalent to diesel fuel. The results showed that ratio of biofuel in blends could increase up to 30% of ethanol with 5% of WCO (called D65E30WCO5) that the engine torque decreased less than 10% whereas exhaust gas emissions reduced significantly. At full load, the average reductions in CO, NO_x, and soot emissions were 28%, 24%, and 13% with D85E10WCO5; 40%, 33%, and 25% with D75E20WCO5; 46%, 41%, and 35% with D65E30WCO5. At the load characteristic curve at engine speed of 2000 rpm, the corresponding reductions were 8.71%, 5.33%, and 5.28% for D85E10WCO5; 9.81%, 5.12%, and 31.78% for D75E20WCO5; 10.11%, 4.81%, and 48.73% for D65E30WCO5. These may result from differences in the fuel properties between the blends and diesel fuel.

Keywords: Biofuel, waste cooking oil, ethanol, emissions, diesel engine.

1. Introduction

Currently, the depletion of fossil fuels and environmental pollution problems have increased global interest in alternative fuels. Study and application of alternative fuels in general, biofuels in particular which are renewable and environmentally friendly, on internal combustion engines have become urgent need. Development of biofuels not only addresses the issues of energy shortages and environmental pollution but also contributes to economic development and increases the income of people in rural areas.

Previous studies have shown that vegetable oil can be used as a fuel for diesel engines due to its high cetane number and calorific value, which are comparable to those of mineral diesel fuel. However, issues such as high viscosity and low volatility have negatively impacted the fuel injection process and exhaust emissions quality [1]. Solutions to these problems include increasing the fuel temperature, blending vegetable oil with diesel or ethanol, and converting vegetable oil into methyl esters. Ethanol is also an attractive alternative fuel because it is renewable, has a biological origin, and contains a high oxygen content, thereby offering the potential to reduce exhaust gas emissions. Some studies have initially applied blend of diesel, ethanol and vegetable oil as fuel for diesel engines. D.H.Qi.'s research on engine performance,

emissions and combustion process of a diesel engine using a blend of rapeseed oil, diesel, and ethanol with oleic acid as surfactant and 1-butanol as co-surfactant [1] indicated that a high proportion of rapeseed oil mixed with diesel fuel could be used directly in diesel engines without engine modification. However, the fuel consumption rate, smoke, CO and HC emissions of the engine using the blend were higher compared to using fossil diesel due to the high viscosity of rapeseed oil. Adding ethanol to the rapeseed oil-diesel blend can reduce viscosity, improve engine performance, and reduce smoke and NO_x emissions. Al-lwayzy Saddam H. studied the use of MOE20% blend (10% ethanol, 10% microalgae oil, and 80% diesel) in a single-cylinder diesel engine [2]. It concluded that the blend had properties similar to those of fossil diesel highlighting its usability in diesel engine without modification. The results also showed that NO_x and HC emissions decreased at most engine speeds, while CO and CO₂ emissions were lower when using diesel fuel at low engine speeds. Sankumgon Akechai investigated the performance and emissions characteristics of a diesel engine using jatropha oil-diesel-ethanol fuel blends [3]. The results indicated that blends with a low ethanol ratio (5%) provided engine power, fuel consumption, and exhaust gas temperature similar to those of diesel, with CO and CO₂ emissions decreasing as the ethanol ratio increased. The author also concluded the blends could

be used as a biofuel in current diesel engines without major modification. Syarifudin studied the use of a blend of 75% diesel, 10% jatropha oil, and 15% butanol (DJ10B15) on an unmodified Isuzu 4JB1 direct injection diesel engine [4]. In case of using the blend, the engine performance was similar but soot was lower than the case of diesel fueling. Taib Iskandar Mohamad researched the use of Waste Cooking Oil (WCO) - diesel blends [5] and found that engines using blends containing 10%-30% WCO had power and fuel consumption levels similar to those using diesel, with slightly higher CO emissions but lower CO₂ and NO_x emissions.

Thus, it can be seen that blending ethanol with vegetable oil and/or WCO has the potential to replace mineral diesel as fuel for diesel engines without major engine modifications [1, 5]. With a reasonable blending ratio, the performance of diesel engine changes little, while reducing some harmful components in the engine's exhaust emissions.

In Vietnam, research on the use of biofuels is also of great interest. Currently, seven ethanol production plants have been constructed, of which six have been come into operation with a total design capacity of 500.000 m³ per year. However, ethanol is currently only blended at ratio of 5% with gasoline (called E5) for use in gasoline engines. The consumption of E5 nationwide has remained low in recent years and shows a decreasing trend [6]. Research on using diesel-ethanol-WCO fuel blends with a higher ethanol ratio will enhance the replacement of mineral diesel, improve engine emissions and promote the potential of bioethanol production in Vietnam. Moreover, increasing biofuel use also contributes to implement the commitment of the government to achieve net-zero emissions by 2050 and the Decision No. 876/QD-TTg approving the Action Program on green energy transition and reducing carbon and methane emissions in the transportation sector [7].

2. Simulation Models in AVL Boost Software

The diesel engine is simulated by AVL Boost software based on some main models such as thermodynamic model, combustion model, fuel model, heat transfer model, and emissions model [8].

2.1. Thermodynamic Model

The thermodynamic state of the air-fuel mixture in the engine cylinder is calculated based on the first law of thermodynamics as following:

$$\begin{aligned} \frac{d(m_c \cdot u)}{d\alpha} = & -p_c \cdot \frac{dV}{d\alpha} + \frac{dQ_F}{d\alpha} - \sum \frac{dQ_w}{d\alpha} - h_{BB} \cdot \frac{dm_{BB}}{d\alpha} + \\ & + \sum \frac{dm_i}{d\alpha} \cdot h_i - \sum \frac{dm_e}{d\alpha} \cdot h_e - q_{ev} \cdot f \cdot \frac{dm_{ev}}{dt} \end{aligned} \quad (1)$$

The change in mass within the cylinder is calculated by the total mass entering and exiting the cylinder:

$$\frac{dm_c}{d\alpha} = \sum \frac{dm_i}{d\alpha} - \sum \frac{dm_e}{d\alpha} - \frac{dm_{ev}}{d\alpha} + \frac{dm_{ev}}{dt} \quad (2)$$

where, m_c : mass in the cylinder, u : specific internal energy, p_c : pressure cylinder, V : cylinder volume, Q_F : fuel energy, Q_w : wall heat loss, α : crank angle, h_{BB} : enthalpy of blow-by, m_{BB} : blow-by mass flow, m_i : mass element flowing into the cylinder, m_e : mass element flowing out of the cylinder, h_i : enthalpy of the in-flowing mass, h_e : enthalpy of the mass leaving the cylinder, q_{ev} : evaporation heat of the fuel, f : fraction of evaporation heat from the cylinder charge, m_{ev} : evaporating fuel.

The equation of state for the gas in the cylinder is

$$p_c = \frac{1}{V} \cdot m_c \cdot R_c \cdot T_c \quad (3)$$

By combining (2) and (3), it is possible to determine the temperature and pressure within the engine cylinder.

2.2. Heat Transfer Model

The heat transfer processes from the combustion chamber through components such as the cylinder head, piston and cylinder wall are calculated using the following formula:

$$Q_{wi} = A_i \cdot \alpha_w \cdot (T_c - T_{wi}) \quad (4)$$

where: Q_{wi} : wall heat flow, A_i : surface area, α_w : heat transfer coefficient, T_c : gas temperature in the cylinder, T_{wi} : wall temperature.

The Woschni 1978 model was chosen for calculating the heat transfer coefficient:

$$\alpha_w = 130 \cdot D^{-0.2} \cdot p_c^{0.8} \cdot T_c^{-0.53} \left[C_1 \cdot c_m + C_2 \cdot \frac{V_D \cdot T_{c,1}}{p_{c,1} \cdot V_{c,1}} \cdot (p_c - p_{c,0}) \right]^{0.8} \quad (5)$$

2.3. Combustion Model

The combustion model used in the study is the AVL MCC model, where the total heat release rate in the cylinder ($\frac{dQ_{total}}{d\alpha}$) is the sum of the heat release rate during

the premixed combustion phase $\frac{dQ_{PMC}}{d\alpha}$ and the diffusion combustion phase (mixing combustion phase) $\frac{dQ_{MCC}}{d\alpha}$

according to the equation:

$$\frac{dQ_{total}}{d\alpha} = \frac{dQ_{MCC}}{d\alpha} + \frac{dQ_{PMC}}{d\alpha} \quad (6)$$

Table 1. Reactions in NO_x formation mechanism

	Stoichiometry	Rate	K ₀ [cm ³ ,mol,s]	A [-]	T _A [K]
		$K_i = k_{0,i} \cdot T^a \cdot e^{\left(\frac{-T A_i}{T}\right)}$			
R ₁	N ₂ +O=NO+N	$r_1 = k_1 \cdot c_{N_2} \cdot c_o$	4.93E13	0.0472	38048.01
R ₂	O ₂ +N=NO+N	$r_2 = k_2 \cdot c_{O_2} \cdot c_N$	1.48E08	1.5	2859.01
R ₃	N+OH=NO+H	$r_3 = k_3 \cdot c_{OH} \cdot c_N$	4.22E13	0.0	0.0
R ₄	N ₂ O+O=NO+NO	$r_4 = k_4 \cdot c_{N_2O} \cdot c_o$	4.58E13	0.0	12130.6
R ₅	O ₂ +N ₂ =N ₂ O+O	$r_5 = k_5 \cdot c_{O_2} \cdot c_{N_2}$	2.25E10	0.825	50569.7
R ₆	OH+N ₂ =N ₂ O+H	$r_6 = k_2 \cdot c_{OH} \cdot c_{N_2}$	9.14E07	1.148	36190.66

The heat released during the diffusion combustion phase is a function of the available fuel quantity (f_1) and the turbulent kinetic energy density (f_2):

$$\frac{dQ_{MCC}}{d\alpha} = C_{Comb} \cdot f(m_F, Q_{MCC}) \cdot f_2(k, V). \quad (7)$$

The rate of heat release during the premixed combustion phase is described by the Vibe function:

$$\left(\frac{dQ_{PMC}}{Q_{PMC}}\right) \frac{d\alpha}{d\alpha_c} = \frac{a}{\Delta\alpha_c} \cdot (m+1) \cdot y^m \cdot e^{-a \cdot y^{(m+1)}} \quad (8)$$

2.4. Emissions Model

The formation of NO_x is based on the Zeldovich mechanism, which is represented by a series of reaction equations [8], Table 1 shows the rate of NO_x production for six reactions.

The concentrations of N₂O and NO are calculated using the following formulas:

$$C_{N_2O} = 1.1802 \cdot 10^{-6} T^{0.6125} \cdot e^{\left(\frac{9471.6}{T}\right)} \cdot C_{N_2} \cdot \sqrt{p_{O_2}} \quad (9)$$

$$r_{NO} = C_{PostProMult} \cdot C_{KineticMult} \cdot 2(1-\alpha^2) \frac{r_1}{1+\alpha \cdot AK_2} \frac{r_4}{1+AK_4} \quad (10)$$

with
$$\alpha = \frac{C_{NO,act}}{C_{NO,equ}} \cdot \frac{1}{C_{PostPr oMult}}; AK_2 = \frac{r_1}{r_2 + r_3};$$

$$AK_4 = \frac{r_4}{r_5 + r_6}$$

The CO emissions are calculated using the following formula:

	Stoichiometry	Rate
R ₁	CO+OH=CO ₂ +H	$r_1 = 6.76 \cdot 10^{10} \cdot e^{\left(\frac{T}{1102.0}\right)} \cdot C_{CO} \cdot C_{OH}$
R ₂	CO+O ₂ =CO ₂ +O	$r_2 = 2.51 \cdot 10^{12} \cdot e^{\left(\frac{-24055.0}{T}\right)} \cdot C_{CO} \cdot C_{O_2}$

The final rate of CO production/destruction in [mole/cm³s] is calculated as:

$$r_{CO} = C_{const} \cdot (r_1 + r_2) \cdot (1-\alpha) \quad (11)$$

with
$$\alpha = \frac{C_{CO,act}}{C_{CO,equ}}$$

The soot emissions in the simulation are calculated based on the following equation [8]:

$$\frac{dm_{soot}}{dt} = \frac{dm_{soot,form}}{dt} + \frac{dm_{soot,ox}}{dt} \quad (12)$$

with:
$$\frac{dm_{soot,form}}{dt} = A_{form} \cdot \frac{dm_{fuel}}{dt} \Big|_{diff} \left(\frac{p_{cyl}}{p_{ref}}\right)^{n_1} e^{\frac{T_{a-form}}{T_{ave}}}$$

$$\frac{dm_{soot,ox}}{dt} = A_{ox} \cdot \frac{1}{\tau_{char}} (m_{soot})^{n_2} \cdot \left(\frac{p_{O_2}}{p_{O_2,ref}}\right)^{n_3} \cdot e^{\frac{T_{a-ox}}{T_{ave}}}$$

where

A_{form} : soot formation factor [-]

A_{ox} : soot oxidation factor [-]

τ_{char} : characteristic mixing time [°CA]

m_{fuel} : mass of fuel burned [kg]

T_{a-form} : activation temp: soot formation [K]

T_{a-ox} : activation temp: soot oxidation [K]

T_{ave} : average in-cylinder temperature [K]

p_{cyl} / p_{ref} : normalized in-cylinder press [-]

$p_{O_2} / p_{O_2,ref}$: normalized oxygen partial press [-]

n_1, n_2, n_3 : model factor [-]

2.5. Fuel Model

The fuel used in the calculations is fully defined by its physical, chemical, and thermal properties according to the following equations:

$$\frac{C_p}{R} = a_1 + a_2T + a_3T^2 + a_4T^3 + a_5T^4 \quad (13)$$

$$\frac{H^0}{RT} = a_1 + \frac{a_2}{2}T + \frac{a_3}{3}T^2 + \frac{a_4}{4}T^3 + \frac{a_5}{5}T^4 + \frac{a_6}{T} \quad (14)$$

$$\frac{S^0}{RT} = a_1 \ln T + a_2T + \frac{a_3}{2}T^2 + \frac{a_4}{3}T^3 + \frac{a_5}{4}T^4 + a_7 \quad (15)$$

where C_p is the specific heat capacity at constant pressure, H^0 is the enthalpy, S^0 is the entropy and a_1 to a_7 are constants determined for each type of fuel.

3. Performance and Emissions of a D4BB Diesel Engine Using a Diesel-Ethanol-WCO Fuel Blend

3.1. Developing and Verifying the Reliability of the Model

The engine used in the study is a D4BB diesel engine, a 4-cylinder inline engine equipped with a mechanical fuel system, commonly powered Hyundai

1.25-ton truck model in Vietnam. The main technical specifications of the engine are shown in Table 2 [9].

The blends of fossil diesel, ethanol, and WCO, including D65E30WCO5 (65% diesel-30% ethanol-5% WCO), D75E20WCO5 (75% diesel-20% ethanol-5% WCO), and D85E10WCO5 (85% diesel-10% ethanol-5% WCO) are used in this study. The main properties of the base fuels are presented in Table 3 [1, 12-14].

According to the Kendall-Monroe viscosity calculation formula [10], the viscosities of the blends D65E30WCO5, D75E20WCO5, and D85E10WCO5 are 2.72 mm²/s, 2.92 mm²/s, and 3.12 mm²/s respectively, which meet the viscosity requirement equivalent to diesel (2-4.5 mm²/s) [11]. In Vietnam, with the advantage of abundant ethanol production resources, while the availability of WCO is insufficient to meet the demand for internal combustion engine fuel. Therefore, this study uses blends with ethanol content as high as 30%, while WCO maintains only 5% as an additive. This approach aims to meet the viscosity standards of the fuel while also maximizing the potential of ethanol production resources in Vietnam. The input parameters for the fuel model are listed in Table 4 [8].

Table 2. Technical specifications of the D4BB diesel engine

No	Specifications	Value
1	Engine model (D4BB)	Diesel, 4-stroke, 4-cylinder inline, naturally aspirated
2	Firing order	1-3-4-2
3	Swept volume (liter)	2.607
4	Bore x Stroke (mm)	91.1 × 100
5	Early injection angle (degree)	20
6	Connecting rod length (mm)	158
7	Rated power/engine speed (kW/rpm)	59/4000
8	Maximum torque/engine speed (Nm/rpm)	165/2200
9	Compression ratio (ε)	22

Table 3. Properties of the fuels

Fuel properties	Diesel	Ethanol	WCO
Density at 15 °C (g/mL)	0.823	0.8314	0.91
Kinematic viscosity at 40 °C (mm ² /s)	2.84	1.2	42.5
Lower calorific value (kJ/kg)	42636	26778	37680
Oxygen content (wt %)	0	34.8	20
Flash point (°C)	78	13	271
Cetane number	46	5-8	54
Latent heat of vaporization (kJ/kg)	250	840	-

Table 4. Input parameters for the fuel model

Parameters	Fuels					
	Diesel	Ethanol	Palmitic Acid	Oleic Acid	Linoleic Acid	Stearic Acid
Coefficient a_1 (high/low temperature)	18.930/ -2.766	6.5624/ 4.8587	36.309/ 18.670	40.550/ 20.430	40.051/ 17.096	40.967/ 20.686
Coefficient a_2 (high/low temperature)	0.048/ 0.098	0.0152/ -0.0037	0.0985/ -0.0029	0.104/ -0.001	0.0990/ 0.0213	0.1094/ -0.0031
Coefficient a_3 (high/low temperature)	-1.682/ -3.4953	-5.389/ 6.9555	-3.556/ 0.0004	-3.740/ 0.0004	-3.5648/ 0.0003	-3.945/ 0.0004
Coefficient a_4 (high/low temperature)	2.6960/ -2.2993	8.6225/ -8.8655	5.7569/ -5.2473	6.0448/ -5.6862	5.7614/ -4.9420	6.3822/ -5.9585
Coefficient a_5 (high/low temperature)	-1.658/ 1.5849	-5.128/ 3.5169	-3.452/ 2.0622	-3.621/ 2.2501	-3.4514/ 1.9752	-3.825/ 2.3529
Coefficient a_6 (high/low temperature)	-9409/ -3196.5	-3267/ -1738.3	-20105/ -8094	-21959/ -8888	-21381/ -8405	-22543/ -9025
Coefficient a_7 (high/low temperature)	-78.81/ 35.19	-9.473/ 4.8018	-161.8/ -34.809	-180.88/ -38.91	-178.65/ -26.55	-185.2/ -40.492

Based on the theoretical background outlined above, the D4BB diesel engine is modeled in the AVL Boost software as shown in Fig. 1, with the model components corresponding to the various engine parts.

The reliability of the model is evaluated by comparing the simulation results with experimental data according to the engine performance curves using diesel fuel. The testing was conducted at the Research Center for Propulsion Systems and Autonomous Vehicles, School of Mechanical Engineering, Hanoi University of Science and Technology. The simulated and experimental engine power at full load modes is displayed in Fig. 2. It is showed that the maximum deviation in engine power is 4.55% at 3000 rpm, with an average deviation in power over the speed range of 2.91%. The maximum deviation in specific fuel consumption is 3.67% at 1500 rpm, with an average deviation over the speed range of 2.83%.

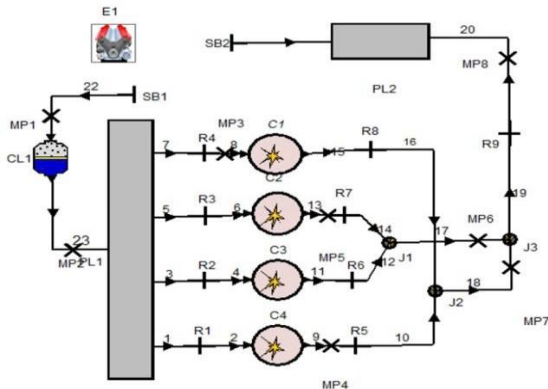

Fig. 1. Hyundai D4BB engine model

The simulated cylinder pressure at 2000 rpm agrees quite well with the experimental results as shown in Fig. 3. The relative difference in peak cylinder pressure is about 0.36% (Fig. 3).

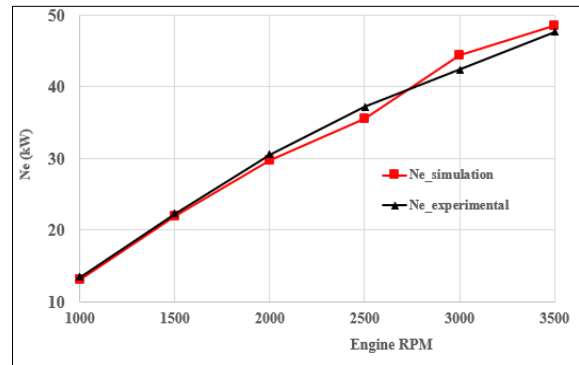

Fig. 2. Engine power at full load

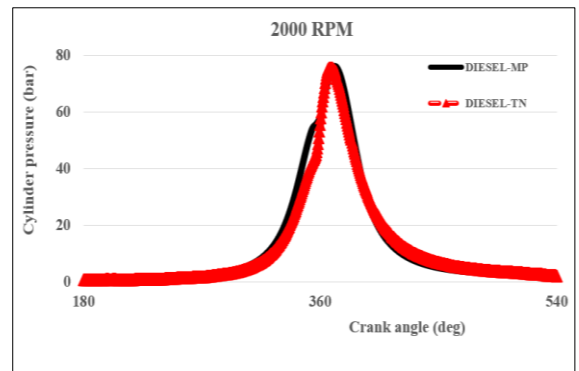

Fig. 3. Engine cylinder pressure at full load, 2000 rpm

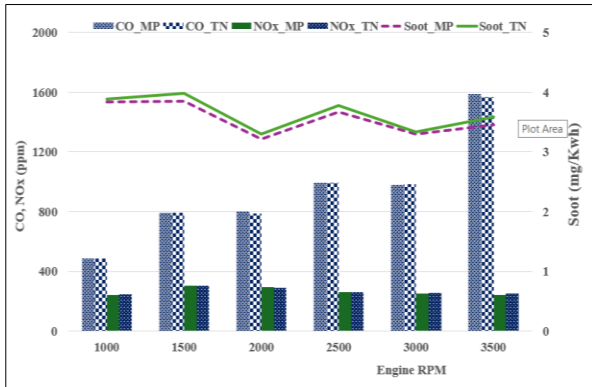

Fig. 4. CO, NO_x and soot emissions

Fig. 4 shows the CO, NO_x and soot emissions in simulation and experimentation. The maximum CO deviation is 0.95% at 3500 rpm, with an average deviation of 0.17% across the entire speed range. The maximum NO_x deviation is 2.53% at 2000 rpm, with an average deviation of 0.02% over the speed range. The maximum soot deviation is 3.99% at 1500 rpm, with an average deviation of 2.17%. With deviations between simulation and experimental results less than 5%, the engine model is considered reliable for simulating mixed fuel types.

3.2. Engine Performance and Emissions

3.2.1. Simulation mode:

+ *At full load:* 100% load with speed varies from 1000 rpm to 3500 rpm. Amount of fuel per cycle at each mode is shown in Table 5. These values were determined by experiment with diesel fuel and kept similar with different blends during simulation work.

+ *At load characteristics curve:* Load conditions of 25%, 50%, 75%, and 100% at 2000 rpm, with corresponding torque values using diesel fuel as shown in Table 6.

3.2.2. Comparison of engine power and fuel consumption

Fig. 5 illustrates engine power according to the performance curves for various fuel types. Engine power increases with engine speed, and the performance curves for the mixed fuels show a similar trend to diesel fuel. The engine achieves its highest power with diesel, reaching 48.45 kW at 3500 rpm. For the blends, the maximum power is 46.56 kW for D85E10WCO5, 45.06 kW for D75E20WCO5, and 43.61 kW for D65E30WCO5. An increase in the ethanol content in the blend tends to reduce engine power. On average over the speed range, the power decreases by 3.43%, 6.38%, and 9.36% for D85E10WCO5, D75E20WCO5, and D65E30WCO5, respectively, compared to diesel. The reduction in power is due to significantly lower heating value of ethanol as compared to diesel, which lowers the heating value of the blends and consequently reduces engine power.

Table 5. Fuel quantity per cycle supplied at each engine speed

Engine speed (rpm)	1000	1500	2000	2500	3000	3500
Fuel per cycle g _{ct} (g/cycle)	0.027	0.0285	0.035	0.03	0.032	0.03

Table 6. Engine torque modes at 2000 rpm

% load	25%	50%	75%	100%
Engine torque (Nm)	36.56	71.4	106.08	143.85
Fuel per cycle diesel	0.012	0.0185	0.026	0.03
Fuel per cycle D85E10WCO5	0.01227	0.019	0.02798	0.0311
Fuel per cycle D75E20WCO5	0.01265	0.01992	0.02805	0.03227
Fuel per cycle D65E30WCO5	0.01299	0.02072	0.0291	0.0336

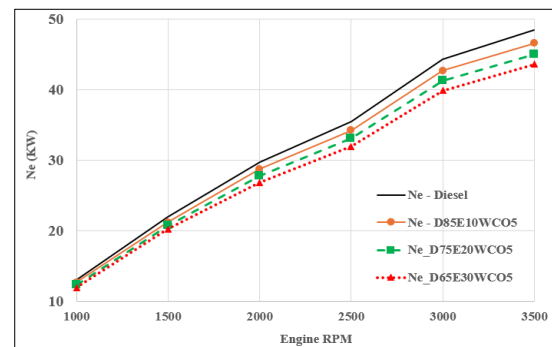

Fig. 5. Engine power at full load

Fig. 6 and Fig. 7 show the fuel consumption of the engine. Compared to diesel, the fuel consumption when using the fuels D85E10WCO5, D75E20WCO5, and D65E30WCO5 increases on average by 3.56%, 6.83%, and 10.34% over the full load curve, and by 2.75%, 7.09%, and 11.37% over the load characteristic curve at 2000 rpm. The lower calorific value of ethanol reduces the overall calorific value of the blends, leading to an increase in fuel consumption.

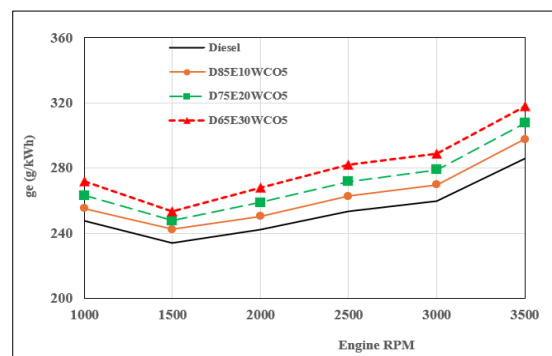

Fig. 6. Fuel consumption at full load

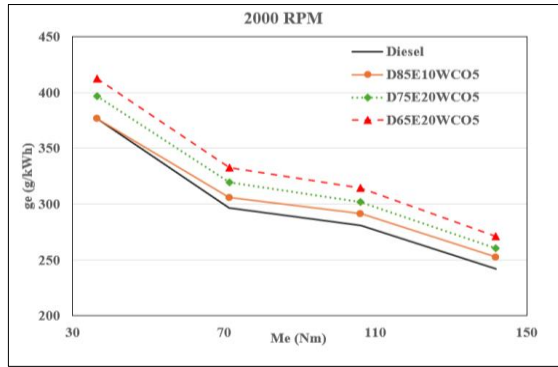

Fig. 7. Fuel consumption rate at different loads, 2000 rpm

The engine cylinder pressure depends on the fuel composition being burned and the crankshaft angle of the engine. Fig. 8 shows the engine cylinder pressure at full load and speed of 2000 rpm. The peak cylinder pressure for diesel is 75.88 bar, while for D85E10WCO5 it is 75.86 bar. For D75E20WCO5 the peak cylinder pressure reaches 75.73 bar, and for D65E30WCO5 it is 75.37 bar at around 370° crankshaft angle. According to the characteristic curve at 25% load and a speed of 2000 rpm, the cylinder pressure is 60.34 bar for diesel, 59.25 bar for D85E10WCO5, 60.59 bar for D75E20WCO5, and 60.86 bar for D65E30WCO5 at a crankshaft angle of 363° as displayed in Fig. 9.

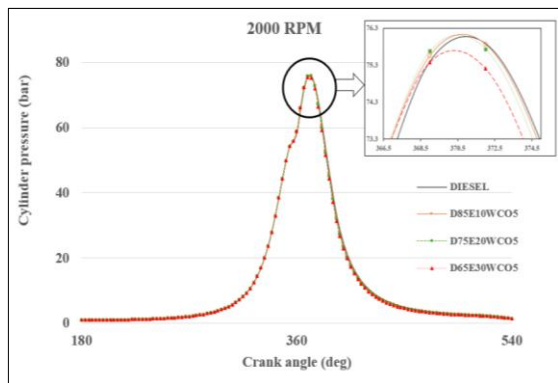

Fig. 8. Cylinder pressure at full load, 2000 rpm

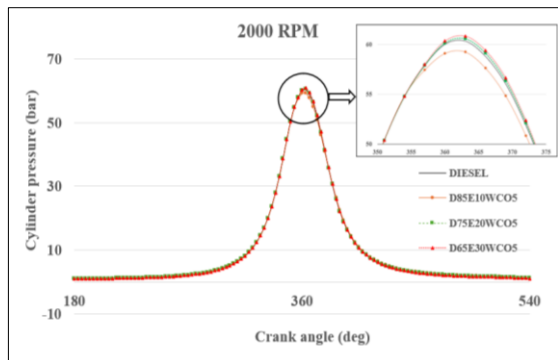

Fig. 9. Cylinder pressure at 36.56 Nm, 2000 rpm

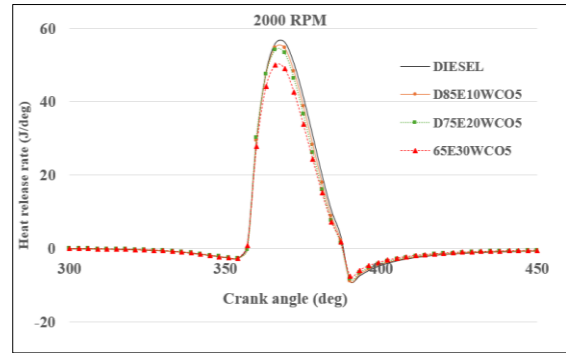

Fig. 10. Heat release rate at full load, 2000 rpm

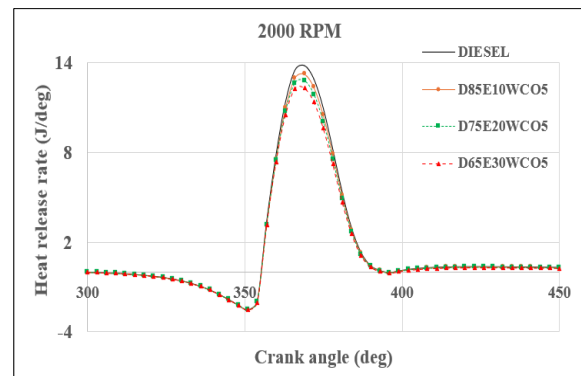

Fig. 11. Heat release rate at 36.56 Nm, 2000 rpm

Fig. 10 shows the heat release rate of the engine at full load and 2000 rpm. At a crankshaft angle of around 369°, the highest heat release rate is 56.20 J/deg for diesel, while for D85E10WCO5, D75E20WCO5, and D65E30WCO5 the corresponding values are 54.62 J/deg, 53.24 J/deg, and 49.11 J/deg. At 25% load and 2000 rpm, the maximum heat release rate for diesel is 13.80 J/deg, for D85E10WCO5, D75E20WCO5, and D65E30WCO5 the values are 13.24 J/deg, 12.78 J/deg, and 12.31 J/deg at a crankshaft angle of around 369° as seen in Fig. 11. The higher the ethanol ratio in the blend, the lower the heat release rate, due to ethanol's lower cetane number and calorific value, which reduces the heat generated from burning the fuel.

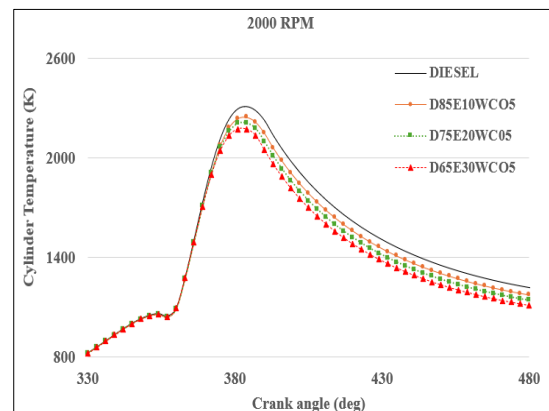

Fig. 12. Cylinder temperature at full load, 2000 rpm

Fig. 12 shows the simulation results of the temperature inside cylinder at full load and 2000 rpm. The highest cylinder temperature is 2306K for diesel, 2244K for D85E10WCO5, 2208K for D75E20WCO5, and 2173K for D65E30WCO5, all occurring at around 383° crankshaft angle. At 25% load and 2000 rpm, the maximum cylinder temperature for diesel is 1379K, while for D85E10WCO5, D75E20WCO5, and D65E30WCO5 the values are 1358K, 1348K, and 1337K at around 378° crankshaft angle as shown in Fig. 13.

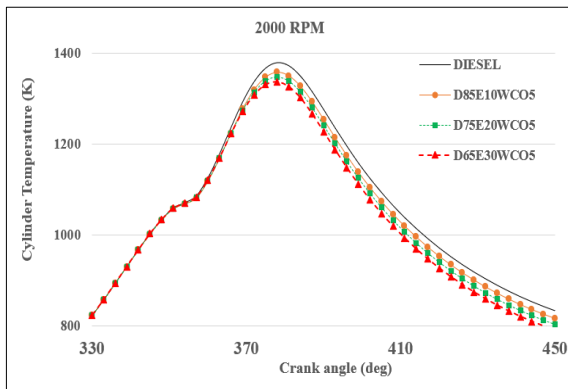

Fig. 13. Cylinder temperature at 36.56 Nm, 2000 rpm

3.3.3. Comparison of emissions

At full load, CO emissions for the D85E10WCO5, D75E20WCO5, and D65E30WCO5 blends are reduced averagely of 28%, 40%, 46% respectively compared to the case of diesel fueling (Fig. 14). At 2000 rpm with varying load, CO emissions for D85E10WCO5, D75E20WCO5, and D65E30WCO5 are reduced by an average of 8.71%, 9.81%, and 10.11% respectively compared to diesel (Fig. 15). CO emissions are produced by incomplete combustion process. The blends have high oxygen content from ethanol (34.8%), and WCO (20%) that promotes combustion completely and leading to lower CO emissions.

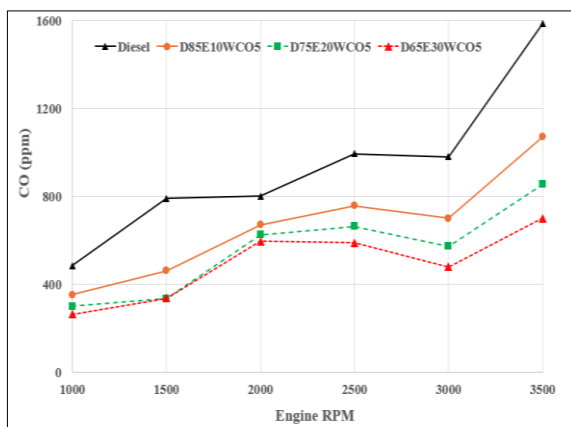

Fig. 14. CO emissions at full load

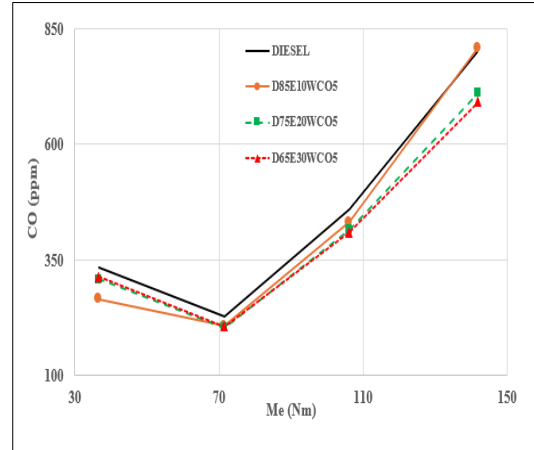

Fig. 15. CO emissions at different loads, 2000 rpm

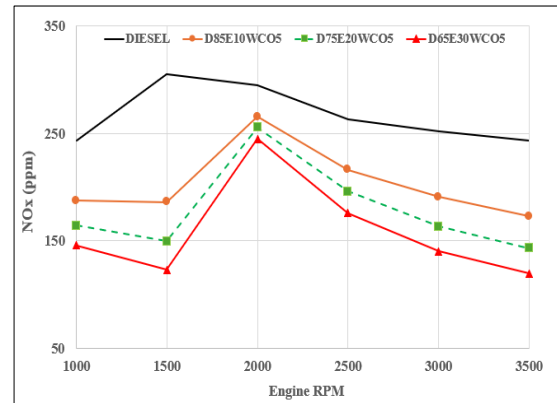

Fig. 16. NO_x emissions at full load

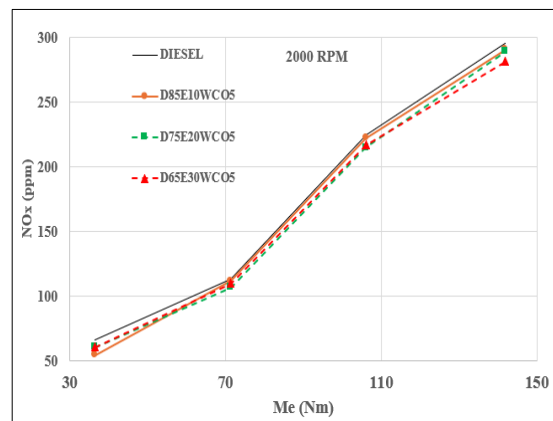

Fig. 17. NO_x emissions at different loads, 2000 rpm

NO_x emissions of the diesel-ethanol-WCO blends tend to decrease as compared to diesel at full load modes. NO_x emissions of D85E10WCO5, D75E20WCO5, and D65E30WCO5 are reduced by an average of 24%, 33%, and 41% respectively compared to diesel (Fig. 16). Following the load characteristics curve at 2000 rpm, NO_x emissions of D85E10WCO5, D75E20WCO5, and

D65E30WCO5 are reduced by an average of 5.33%, 5.12%, and 4.81% respectively compared to diesel (Fig. 17). NO_x emissions depend on the oxygen concentration in the mixture and the peak combustion temperature. The D85E10WCO5, D75E20WCO5, and D65E30WCO5 blends contain ethanol, and WCO with high oxygen content. However, ethanol has a much lower calorific value compared to diesel (26778 kJ/kg versus 42636 kJ/kg), and its higher latent heat of vaporization reduces the combustion temperature, leading to decreased NO_x emissions.

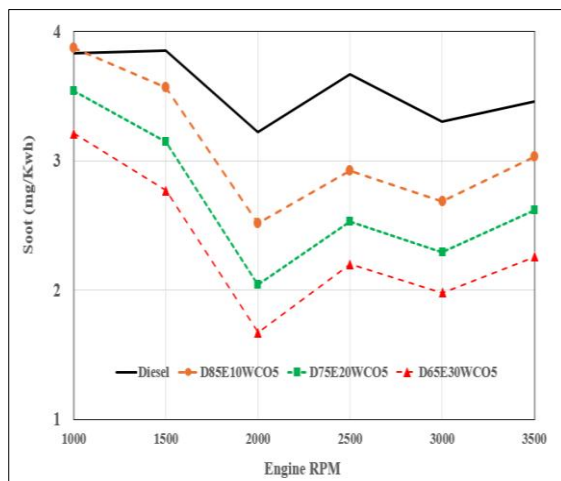

Fig. 18. Soot emissions at full load

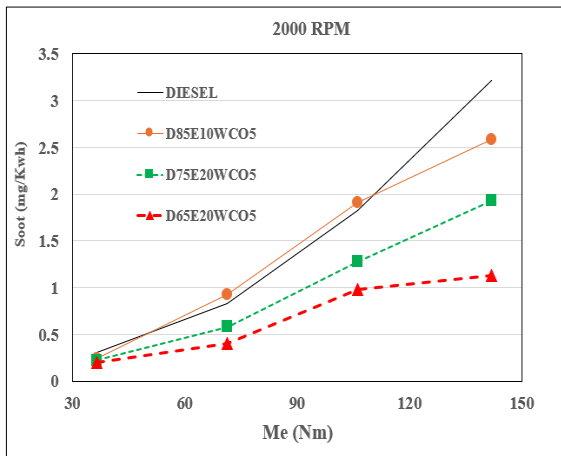

Fig. 19. Soot emissions at different loads, 2000 rpm

Fig. 18 shows the simulation results of soot emissions from the diesel engine at full load conditions. Diesel has the highest soot emissions, whereas D85E10WCO5, D75E20WCO5, and D65E30WCO5 blends reduce soot emissions by an average of 13%, 25%, and 35% respectively compared to diesel. According to the load characteristics curve at 2000 rpm, the soot emissions of D85E10WCO5, D75E20WCO5,

and D65E30WCO5 are reduced by an average of 5.28%, 31.78%, and 48.73% respectively compared to diesel (Fig. 19). The blends containing ethanol, and WCO have high oxygen content, which improves the combustion process and reduces soot emissions.

4. Conclusion

The simulation results have shown the effect of diesel-ethanol-WCO blends on the performance and emissions of D4BB diesel engine used in Vietnam. With the blends D85E10WCO5, D75E20WCO5, and D65E30WCO5 the engine power decreased by 3.43%, 6.38%, and 9.36% respectively, and the specific fuel consumption increased by 3.56%, 6.83%, and 10.34% compared to diesel. This change becomes more noticeable as ethanol content in the blend increases. The emissions CO, NO_x, and soot were significantly improved in case of D65E30WCO5, with the highest reductions being 46% for CO, 41% for NO_x, and 35% for soot as compared to diesel fuel. These results demonstrate the possibility of blending WCO, and ethanol with fossil diesel as fuel for in-used diesel engines that helps to reduce toxic components in diesel exhaust emissions, and also to reduce greenhouse gas emissions because ethanol, and WCO are biofuels.

References

- [1] D. H. Qi, C.F. Lee, P.P. Wang, and S.T. Wu, Effect of ethanol on the performance, emission of a compression ignition engine fuelled with vegetable oil-diesel blend, *International Journal of Ambient Energy*, vol. 37, iss. 3, pp. 284–293, 2016. <https://doi.org/10.1080/01430750.2014.962087>
- [2] Al-lwayzy, Saddam H and Yusaf T., Combustion of microalgae oil and ethanol blended with diesel fuel, *Energies*, vol. 8, iss. 12, pp. 13985–13995, Dec. 2015. <https://doi.org/10.3390/en81212409>
- [3] Sankumgon Akechai, Assawadithalerd Mongkolchai, Phasukarratchai Naphatsarnan, Chollacoop Nuwong, Tongcumpou Chantra, Properties and performance of microemulsion fuel: blending of jatropa oil, diesel, and ethanol- surfactant, *Renewable Energy Focus*, vol. 24, pp. 28–32, Mar. 2018. <https://doi.org/10.1016/j.ref.2017.12.001>
- [4] Syarifudin, and Syaiful, Performance and soot emissions from direct injection diesel engine fueled by diesel-jatropa-butanol-blended diesel fuel, *Journal of Physics: Conference Series*, pp. 1–8, 2020. <https://doi.org/10.1088/1742-6596/1517/1/012103>
- [5] Md. Isa Ali, A. Shahrir, W.M. Faizal, M.T. Iskandar, The use of untreated waste cooking oil and diesel fuel blends as IC engine fuels, *Applied Mechanics and Materials*, vol. 699, pp. 708–713, Nov. 2014. <https://doi.org/10.4028/www.scientific.net/AMM.699.708>
- [6] Nghiem Thi Ngoan, Dao Minh Phuong, Pham Ba Nam, An overview of the gasohol market in Vietnam, the next direction? *Petrovietnam Journal*, vol. 6, pp. 55–62, 2021. <https://doi.org/10.47800/PVJ.2021.06–05>

- [7] Decision No. 876/QD-TTg dated July 22, 2022: Decision Approving the Action Program for Green Energy Transition, Carbon Emission Reduction, and Methane Emission Reduction in the Transportation Sector.
- [8] AVL Boost Theory, Version 2011, AVL. [Online]. Available: <https://www.scribd.com/document/244788918/BOOST-Theory-pdf>
- [9] Industrial Engine Development Team, Model D4BB Shop Manual (for industrial use), Hyundai Motor Co., Inc., 2004.
- [10] Boris Zhmud, Ph.D. Assoc.Prof, MRSC, Viscosity Blending Equations. Lube-Tech. No 121, pp. 22-27, 2014.
- [11] QCVN 01:2022/BKHCN national technical regulation on gasolines, diesel fuel oils and biofuels, 2022.
- [12] Banchapattanasakda Warintorn, Asavatesanupap Channarong, Santikunaporn Malee, Conversion of waste cooking oil into bio-fuel via pyrolysis using activated carbon as a catalyst. *Molecules*, vol. 28, iss. 8, pp. 1–18, Apr. 2023. <https://doi.org/10.3390/molecules28083590>
- [13] Faheem Ahmed Solangi, Investigation of performance and emission characteristics of CI engine using diesel and waste cooking oil blends, *Energies*, vol. 15, iss. 19, pp. 1–15, Sep. 2022. <https://doi.org/10.3390/en15197211>
- [14] S. Nandakumar, Dr. R. Malayalamurthi, Properties of diesel - ethanol blended fuels with surfactan, *International Journal of Engineering Research & Technology (IJERT)*, vol. 4, iss. 11, pp. 72–75, Nov. 2015.